

CONFEZIONATRICE VERTICALE MODELLO VS-600 INOX

*vertical packaging machine
MODEL VS-600 INOX*



packaging division

La confezionatrice VS-600 INOX è una macchina automatica a movimento intermittente specifica per il settore lattiero caseario.

La versione base della macchina è dedicata al confezionamento di mozzarella, adatta all'impiego in ambienti umidi e corrosivi, realizzata completamente in acciaio inox, con parti meccaniche ed elettriche a tenuta stagna. A richiesta possono essere sviluppate linee di confezionamento complete.



The VS-600 INOX packaging machine is an automatic intermittently vertical packaging machine specific for the dairy sector.

The basic version of the machine is dedicated to the packaging of mozzarella, suitable for use in humid and corrosive environments, made entirely of stainless steel, with watertight mechanical and electrical parts.

On request, all kinds of packaging lines and automations can be developed.

OCMA PACKAGING SRL

www.ocmapackaging.it

Via Dei Tretti, 43 36014 Santorso (VI) - Italy

Tel. 0445 1947773 / E-mail : info@ocmapackaging.it

CONFEZIONATRICE VERTICALE MODELLO VS-600 INOX

*vertical packaging machine
MODEL VS-600 INOX*



packaging division

Caratteristiche principali:

- Funzionamento pneumatico
- Touch-screen interfaccia operatore
- Prodotti da confezionare:
formaggi freschi, ciliegine di mozzarella,
bocconcini, fiordilatte, feta, formaggi
grattugiati, ecc.
- Larghezza max bobina 600mm
- Velocità max 50 confezioni/min
- Potenza installata 2500 watt
- Alimentazione elettrica 400volts-50HZ-3Ph+N
- Funzionamento con PLC

Optionals:

- Fotocellula per stampa centrata
- Stampante a caldo
- Immissione liquidi di governo
- Immissione gas inerte

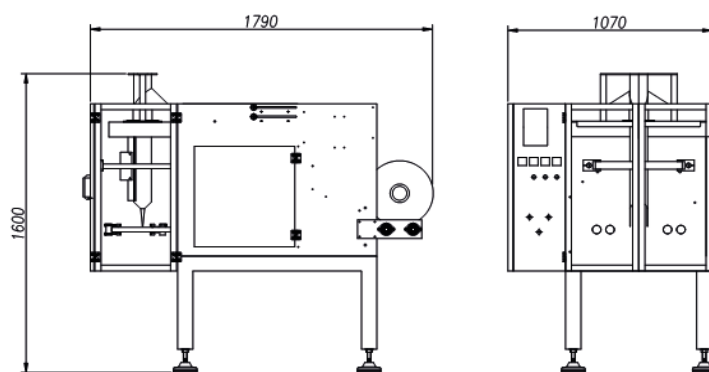

Technical features:

- *Pneumatic function*
- *Touch-screen operator interface*
- *Products to be packaged interface:
fresh cheeses, mozzarella cherries, morsels,
fiordilatte, feta, grated cheeses, etc.*
- *Installed power 2500 watts*
- *Electrical Power supply 400volts-50Hz-3Ph+N*
- *Functional with PLC*

Optionals:

- *Photocell for centered printing*
 - *Hot Printer*
- *Liquid input government*
 - *Inerte gas input*

OCMA PACKAGING SRL

www.ocmapackaging.it

Via Dei Tretti, 43 36014 Santorso (VI) - Italy

Tel. 0445 1947773 / E-mail : info@ocmapackaging.it